

BAKER

Products



Baker AB/ABX Band Resaw User Manual

Ellington Industrial Supply, Inc.

P. O. Box 128

Ellington, Missouri 63638 USA

Web site: www.baker-online.com E-mail: info@baker-online.com

Phone: (573) 663 – 7711 Fax: (573) 663 – 2787



TABLE OF CONTENTS

1	INTRODUCTION	3
	Machine Purpose	3
	Machine Function	3
	Definition of Terms	4
	Manual Contents Notice	5
	Machine Specifications and Requirements	5
	Warranty	6
	Defective Parts	7
	Service Policy	7
2	RULES FOR SAFE OPERATION	8
	Safety Expectations for Operating Power Equipment	8
	Control of Hazardous Energy – (Lockout / Tagout)	9
3	MACHINE FEATURES	10
4	SET-UP	11
	Receiving and Inspection	11
	Unpacking	11
	Machine Moving	11
	Machine Positioning	11
	Power and Utilities Requirements	11
	Operator Training	12
5	CHANGING BLADES	13
	Removing Blade	13
	Installing New Blade	13
	Blade Tracking	14
	Checking the Tracking	14
	Drive Wheel Adjustments	15
	Idler Wheel Adjustments	15
	Vertical Adjustments	15
	Horizontal Adjustments	16
	Cutting Angle Adjustments	17
	Determining the Problems	17
	Front-to-Back Adjustments	18
	Side-to-Side Adjustments	18
6	SETTING GUIDES	19-20
7	FEEDWORKS	21
	Feed Speed	21
	Hydraulics	21
	Conveyor Belts	21
	Powered Hold-Down	22
8	OPTIONAL EQUIPMENT	23
9	BLADES	24
10	MAINTENANCE TASK CHECKLIST	25
	Trouble Shooting	26
	Parts and Service	27
	Recommended Spare Parts	27
	Service Contact Information	27
	Serial Number Location	27
	Wiring Diagrams	28-29



INTRODUCTION

Thank you and congratulations on the purchase of your new **Baker AB/ABX Band Resaw**. It has been designed to be durable, productive and easy to use. When properly ran and maintained, it will provide you with many years of profitable operation.

For safety reasons, and for your own best use of the **Baker AB/ABX Band Resaw**, we insist that you read this manual fully, and constantly review and refer back to it as necessary.

No one should attempt to operate or perform maintenance on this equipment until they have been trained and taken the time to read and understand the information contained in this manual.

**** FAILING TO DO SO MAY RESULT IN SERIOUS INJURY ****

Machine Purpose

The **Baker AB/ABX Band Resaw** was designed to save space with a compact footprint, yet gives you the same great features of larger band resaws. The head rig can be adjusted up or down while the conveyor stays at a fixed height making it easier to interchange and integrate with other material handling systems.



Machine Function

The **Baker AB Band Resaw** is equipped with a 20 HP electric motor and accepts material up to 6" x 12" (15 cm x 30 cm) and uses a 6" wide conveyor while the **Baker ABX** is equipped with a 30 HP electric motor and accepts material up to 12" x 12" (30 cm x 30 cm) with a 12" conveyor. Both models are capable of variable speeds from 0 – 95 feet per minute as well as Baker's exclusive guide system that includes guide plates and guide roller.



Definition of Terms

All Stop	Safety button (typically “red”) designed to immediately shut-down machine operation
Band Saw	A saw consisting of a continuous piece of flexible steel, with teeth on one side
Board Foot or Board Feet	A form of measurement where one board foot equals the volume of a board 1 inch thick by 12 inches wide and 12 inches long
Cant	The 3 or 4 sided timber left over from a log, normally the center or core of the log
Cant Hook	A device used for rolling cants or logs
Carriage	A framework on wheels that allows movement of a log back and forth past the saw blade
CFM (cubic feet per minute)	A measure of the volume of a <u>substance flowing through air</u> within a fixed period of time
Edge Guide	A straight edge that is used to guide a 3-sided flitch along a piece of material
Edger	A sawmill machine used to remove wany edges from flitches after they come off the head rig, squaring the edges and ripping the flitch into lumber
End Stop	A mechanism designed to stop the progress of an off-loading board
Fence (Arm)	A straight guide used to keep a log, cant or board a set distance from a blade or cutter
Flitch	A longitudinal section of a log with wany edges
Head Rig or Head Saw	The principle support structures on a sawmill that carries the engine, wheels and band blade used for the initial breakdown of a log
Kerf	The groove or thickness of the path cut by the saw teeth; the total amount of sawdust removed during a single cut
Lift Point	A point where pressure can and should be applied for lifting
Live Rollers	A powered roll case that mechanically moves material
Lockout / Tagout	Requires authorized employee(s) to lock and tag the energy-isolating device(s) to prevent the release of hazardous energy in order to prevent injury to employees, normally while performing maintenance or repairs
Lumber	A longitudinal section of a log after the wany edges have been removed, normally a 4-sided rectangular shaped piece
Off-load	The side of a machine where the work piece (slab, cant, board, etc.) exits
Production Rate	A produced or processed quantity measure with respect to another measured quantity of time; for example number of boards per minute
Roll-case	A mechanical apparatus with elongated cylinders used to perform rolling operation for material movement, can be both powered and/or manually operated
Slab	The exterior portion of a log removed by the saw, having one flat and one rounded portion of a log
Thin Kerf	A relative term, typically referencing band saw blades which are usually thinner than circular saw blades thus resulting in greater lumber recovery
Wany	Waning or diminished in some parts; not of uniform size throughout; sawed boards or timber that is tapered or uneven, from being cut too near the outside of the log
Yield	To generate a return for effort, an amount produced



Manual Contents Notice

This manual is not totally comprehensive. It does not and cannot convey every possible safety and operational problem that may arise while using this machine. The manual will cover many of the basic and specific safety procedures needed in an industrial environment.

All federal and state laws and any regulations having jurisdiction covering the safety requirements for use of this machine take precedence over the statements in this manual. Users of this machine must adhere to such regulations.

Machine Specifications and Requirements

<p>Power: AB = 20HP TEFC ABX = 30HP TEFC</p> <p>Feedworks/Conveyor Motor: Driven by main engine</p> <p>Capacities: AB = 6" x 12"; 6"; wide conveyor ABX = 12" x 12"; 12" wide conveyor</p> <p>Feed Speed: 0 – 95 feet per minute Both AB and ABX models</p>	<p>Dimensions & Weight:</p> <p>Length: 84 in Width: 93 in Height: 68 in Weight: 2,000 lbs</p>	<p>Band Blades: AB = 0.0035" x 1" x 13'2" hardback or 0.035" x 1 ¼" x 13'2" hardback ABX = 0.0035" x 1" x 14'2" hardback or 0.035" x 1 ¼" x 14'2" hardback</p> <p>Kerf: 0.072"</p> <p>Band Wheels: 28 in diameter; all-steel with crown</p> <p>Sawdust Removal: 4" outlet; min. 600 CFM suction recommended at dust removal chute</p>
---	--	---



Warranty

Ellington Industrial Supply, Inc. machinery is warranted against defects in material or workmanship starting from the date of shipment from the manufacturing plant.

This warranty is given solely to the “original purchaser” of the equipment and is in no way to be expressed or implied that it is transferable to any other parties without the written consent and approval from the CEO or Sales Manager of Baker Products.

Our one (1) year warranty period covers all items built at our manufacturing facilities including structural frame, cowlings, doors, shafting, dust chutes and guards.

We honor six (6) months of warranty coverage for miscellaneous vendor-purchased-supplied items including bearings, chain, sprockets, hydraulic components, etc.

Ninety (90) days of warranty coverage is provided on all electrical parts. All electrical components and wiring has been installed in accordance with the National Electrical Code (NEC) of the United States of America.

Ellington Industrial Supply, Inc. does not warranty this machine to meet any other requirements or jurisdiction of any electrical or safety codes of any other state, municipality, other country or jurisdiction. The purchaser assumes all risk and liability whatsoever resulting from the use thereof whether used singularly or in conjunction with other machinery or apparatus, including, but not limited to, all matters resulting from sawdust generation.

Note: *No warranty is provided on any electrical components or parts if equipment is powered or connected to a roto-phase electrical converter in order to create a three phase power supply for operational current from a single phase source.*

Any change in materials, design, or performance intended to improve any product of Ellington Industrial Supply, Inc. shall not obligate Ellington Industrial Supply, Inc. to modify any previously manufactured equipment.

This manual may contain details that if not properly followed can affect the performance of your equipment. You are responsible for proper use and maintenance of your equipment and we reserve the right to deny warranty work if deemed to be caused by a lack of proper maintenance or negligence by the owner or any of their employees.



Defective Parts

Parts claimed defective must be returned freight prepaid, to our plant in Ellington, Missouri. Any part determined defective due to faulty workmanship or materials will be replaced or repaired (at our option) free of charge, F.O.B. our plant. This warranty does not cover expendable items (i.e. drive belts, band wheels, conveyor belting, blades, cutters, guides, etc.). Except as expressly provided herein, this warranty is in lieu of all other warranties, expressed or implied, including a warranty of merchantability or fitness for a particular purpose. This warranty is "void" if any part of the unit has been tampered with, modified, altered, or operated with parts other than supplied or recommended by Ellington Industrial Supply, Inc. In no event shall Ellington Industrial Supply, Inc. be liable for special, indirect, incidental or consequential damages, however arising, including but not limited to, the loss of earnings or the cost of downtime.

Service Policy

In the event that you have any problems, call us at (573) 663-7711 any time between 8:00 AM and 5:00 PM (CST), Monday through Friday. A member of our trained staff will answer any questions you may have. We charge nothing for this service.

The only charge is for replacement parts not covered by warranty or after our inspection we deem that the problem is due to operator error or lack of proper maintenance or neglect.

If it is necessary for a member of our service department to visit your plant at your request, there will be a charge for this service. Call our service department for current prices.

Retain this Information for your Records

Model Number:
Serial Number:
Date of Purchase:
Power Source:.....
Dust Removal:

Ellington Industrial Supply, Inc.

P. O. Box 128





Ellington, Missouri 63638 USA

Web site: www.baker-online.com E-mail: info@baker-online.com

Phone: (573) 663 – 7711 Fax: (573) 663 – 2787

RULES FOR SAFE OPERATION

The purpose of safety symbols and signage is to draw your attention to real or possible hazardous conditions that may exist when operating this equipment. Please remember that safety symbols and signage alone do not eliminate danger and are not substitute for proper training and education regarding operational hazards.

	This symbol and warning indicates a potentially hazardous situation, which, if not avoided, <u>will</u> result in death or serious injury.
	This symbol and warning indicates a potentially hazardous situation, which, if not avoided, <u>could</u> result in death or serious injury.
	This symbol and warning indicates a potentially hazardous situation, which, if not avoided, <u>may</u> result in minor or moderate injury.
	This warning provides notice and instruction regarding a potentially hazardous situation, which, if not avoided <u>will</u> result in serious injury or death.

SAFETY EXPECTATIONS FOR OPERATING POWER EQUIPMENT

ALWAYS...

- ENSURE THAT TRAINED PERSONNEL OPERATE, MAINTAIN AND REPAIR THIS EQUIPMENT
- **TURN POWER OFF AND LOCKOUT / TAGOUT PRIOR TO PERFORMING MAINTENANCE**
- KEEP WORK AREA CLEAN AND WELL LIGHTED TO MINIMIZE OR ELIMINATE HAZARDS
- KEEP CHILDREN AND VISITORS AWAY FROM OPERATING EQUIPMENT
- OPERATE THE EQUIPMENT AT THE RATE IT WAS DESIGNED FOR
- KEEP GUARDS IN PLACE WHEN OPERATING EQUIPMENT
- REMOVE TOOLS BEFORE RESUMING OPERATION
- USE PROPER EXTENSION CORD
- WEAR PROPER APPAREL AND AVOID LOOSE CLOTHING AND ACCESSORIES THAT COULD GET CAUGHT IN MOVING PARTS
- ALWAYS WEAR SAFETY GLASSES AND HEARING PROTECTION
- AVOID "KICK-BACK" BY KNOWING WHAT CONDITIONS CAN CREATE IT
- CHECK DAMAGED PARTS AND REPAIR OR REPLACE THEM IMMEDIATELY

NEVER...

- LEAVE MACHINERY RUNNING OR UNATTENDED, ALWAYS TURN POWER OFF
- OPERATE EQUIPMENT WHEN TIRED, FATIGUED OR UNDER THE INFLUENCE OF DRUGS OR ALCOHOL
- ALLOW UNTRAINED PERSONNEL TO OPERATE, MAINTAIN OR REPAIR THIS EQUIPMENT

No list of safety expectations can ever be complete as every work environment is as different as are the people operating the equipment.

Always keep safety as your highest priority and always use this machine with caution and respect.

Control of Hazardous Energy – (Lockout / Tagout)

Lockout / Tagout (LOTO) refers to specific practices and procedures to safeguard employees from the unexpected energy, startup of machinery/equipment, or the release of hazardous energy during service or maintenance activities.

This requires that a designated individual turn off and disconnect the machinery/equipment from its energy source(s) before performing service or maintenance and that the authorized employee(s) lock and tag the energy-isolating device(s) to prevent the release of hazardous energy and take steps to verify that the energy has been isolated effectively.

List of Related Terms

Affected Employee	An employee whose job requires them to operate a machine or piece of equipment on which service or maintenance is being performed.
Authorized Employee	A person who locks or implements a tagout system procedure on machines or equipment to perform service or maintenance on that machine or equipment. An authorized employee and an affected employee may be the same person when the affected employee's duties also include performing service or maintenance.
Energy Source	Any source of electrical, mechanical, hydraulic, pneumatic, chemical, thermal, or other energy.
Lockout	The placement of a lockout device (such as a lock) on an energy-isolating device, in accordance with an established procedure that ensures the device and the equipment cannot be operated until the lockout device is removed.
Servicing and / or Maintenance	Workplace activities such as constructing, installing, setting up, adjusting, inspecting, modifying, maintaining or servicing machines or equipment. These activities include lubrication, cleaning or un-jamming of machines or equipment, and making adjustments or tool changes where the employee may be exposed to the unexpected energy, start-up of equipment or release of hazardous energy.
Tagout	The placement of a tagout device (such as a tag) on an energy-isolating device, in accordance with an established procedure that ensures the device and the equipment may not be operated until the tagout device is removed.

Example of lockout tags, lockout hasp and keyed lock



The Fatal Five Main Causes of Lockout/Tagout Injuries

1. **Failure to stop equipment**
2. **Failure to disconnect from a power source**
3. **Failure to dissipate (bleed, neutralize) residual energy**
4. **Accidental re-starting of equipment**
5. **Failure to clear work areas before re-starting**

MACHINE FEATURES

We want to highlight the unique and special features of the *Baker AB/ABX Band Resaw*.

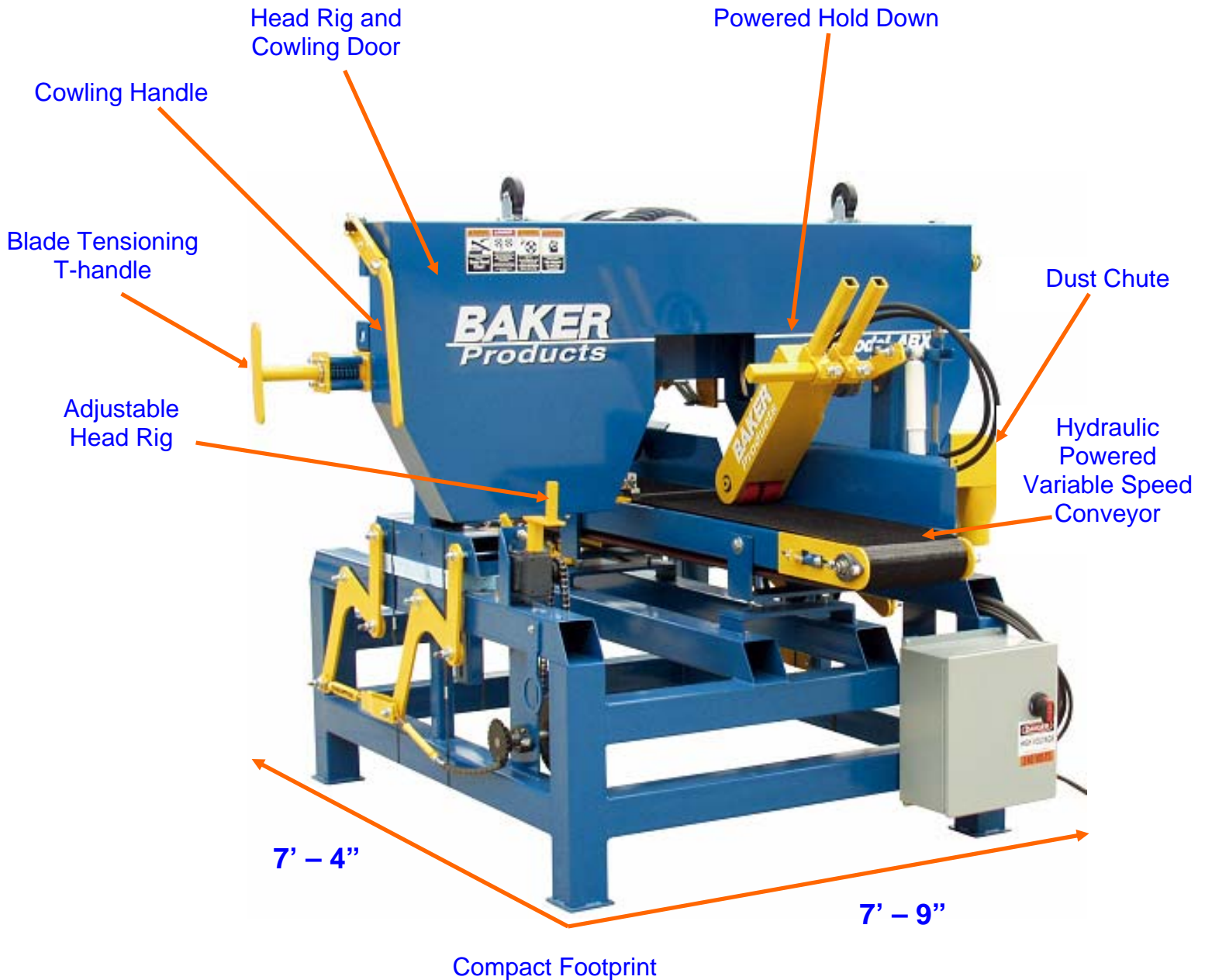



SET-UP

Receiving and Inspection

- Upon receipt and prior to signing transport carrier's documents, conduct a walk-around and visual inspection of your new equipment. Note any damage in writing upon the carrier's bill of lading and contact us immediately.

Note: *All new equipment is assembled and thoroughly tested prior to shipment, however damage may occur during transit, which could cause the machine to not operate correctly during start-up.*

Unpacking

- If machine was delivered via flatbed trailer, remove straps or chains securing it in place.
- If machine was delivered by crate, carefully remove upper crating materials from the base skid.
- Remove lag screws, strapping, etc. that attaches the machine to the skid.

Machine Moving

- Lift machine at the indicated lift points only.
 - o Use a safety strap to avoid tip-over.
- Transport machine to the installation site.

Machine Positioning (*Placement, Leveling, Alignment*)

- For optimum performance, designate a solid and level foundation that is covered and dry, free of environmental elements such as rain or snow that could cause electrical or slip hazards.
- Provide a minimum of 3 feet of clear workspace in front of the electrical panel.
- Provide a minimum of 15 feet of clear workspace in front of in-feed and off-load areas.

Power and Utilities Requirements

- For safe and effective operation confirm your incoming voltage and available amperage is equal to what the machine has been wired for at the factory.



- ***A qualified electrician should complete electrical connections and check for correct motor directional rotation.***

- Ensure all wiring and electrical connections are located in a safe position and away from any hazardous conditions.
- Efficient dust and chip removal requires a minimum of 600 CFM suction at the machine dust removal chute. This is an employer/owner responsibility.



Operator Training

According to many OSHA, ANSI, STATE, and LOCAL CODES, it is the EMPLOYER'S RESPONSIBILITY to:

- Permit only trained and authorized employees to operate and maintain equipment.
- Inspect and maintain guards, safety devices and start/stop controls.
- Instruct, train and supervise the safe method of work.

Be sure personnel are properly trained and safety rules are clearly understood before operating or performing maintenance.

- ✓ **Operator**
- ✓ **Machine**
- ✓ **Guards**
- ✓ **Devices**
- ✓ **Instructions**

*All of these together make up the safety system.
Failure of any one of these factors will increase
accident potential.*

***FREE TRAINING ON PROPER SET-UP AND
OPERATION IS AVAILABLE ON SITE AT
THE MANUFACTURER'S FACILITY***

CHANGING BLADES

Removing Blade

- ❑ Turn power off, allow machine to come to a complete stop, then perform lockout / tagout before proceeding.
- ❑ Use handle on left side of the head rig to lift door until it lies securely over the top of the head rig. **Never open head rig door with blade in motion.**
- ❑ Loosen spring tensioning by turning the T-handle counter-clockwise.
- ❑ Pull down on blade at the top, between the wheels, with your right hand while pushing the top of the left wheel away from you until the left wheel moves. If the blade broke, push the top of the left wheel back with your left hand and pull the wheel toward the right wheel with your right hand.
- ❑ Blade should be loose enough to be removed. Push blade back and off of the right wheel. Pull blade out of guides and remove. If blade is not loose enough to remove from right wheel, go back to the 3rd checklist item above and follow the process again.

Installing New Blade

- ❑ Put blade over the right wheel, through the guides and over the left wheel with teeth facing forward. Be sure the points of the teeth are aimed to the right (toward the dust chute) as they pass through the guides.
- Note:** *It may be necessary to turn the blade inside out.*
- ❑ Make sure the blade gullet is flush with the face of the wheel to avoid knocking out the set.
 - ❑ Turn the spring tensioning T-handle clockwise until one of the spacers makes contact with both compression plates.
 - ❑ Manually turn the wheels to be sure blade is tracking properly.
 - ❑ Close door.

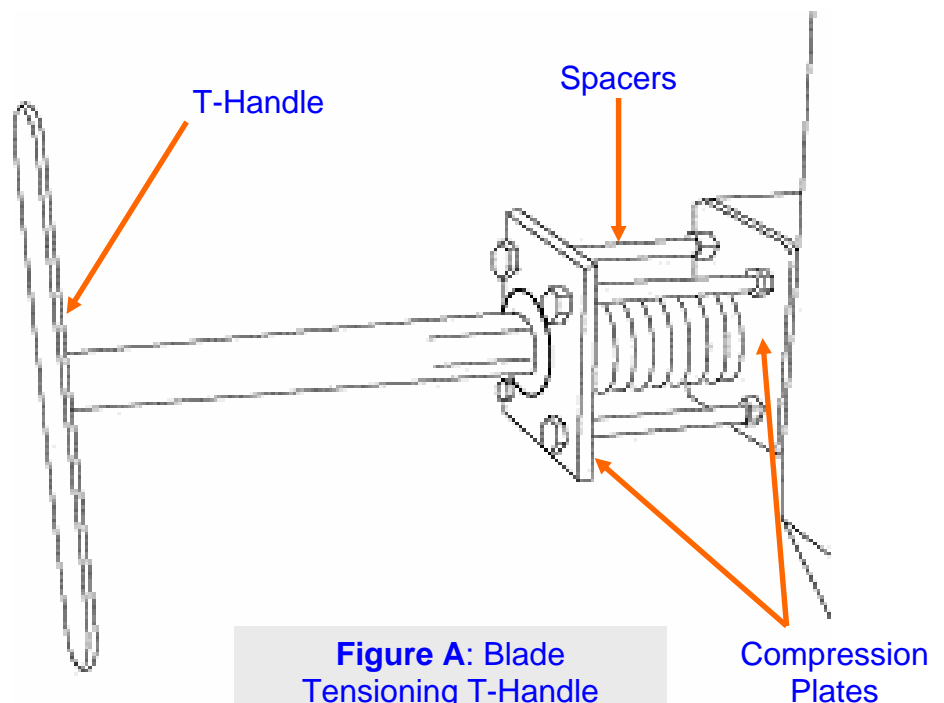

Blade Tracking

The blade must be installed and properly tensioned (see “**Changing Blades**”) before beginning this procedure. Guides should be in a position where they are just barely touching the blade.

The blade tracking is properly set in the factory. It may occasionally be knocked out. This should explain how to check and reset it.

Checking the Tracking

Rotate the idler wheel several rotations counterclockwise. Examine the position of the back of the blade on the wheel at the top of the wheel and compare it to its position at the bottom of the wheel. The blade position should be the same in both locations, on both idler and pull wheels. If not, the tracking should be adjusted.

If tracking appears to be correct after the above procedure, your saw will cut without problems due to blade tracking. However, now rotate the idler wheel several rotations clockwise. Check the blade in the same way as above. If the blade does not track properly “backward” then you may experience hard-to-identify problems, which may limit your saw’s capabilities. In this case, it is advisable to adjust the tracking using the following procedures.

An important starting point for proper tracking is to ensure the face of the wheels align with one another. This can be checked with a straightedge. Use this method to start setting the tracking using the adjusters shown in the illustration below.

All adjustments for blade tracking are located on the backside (motor side) of the head rig on the square tube with the spring tensioning assembly located on one end.

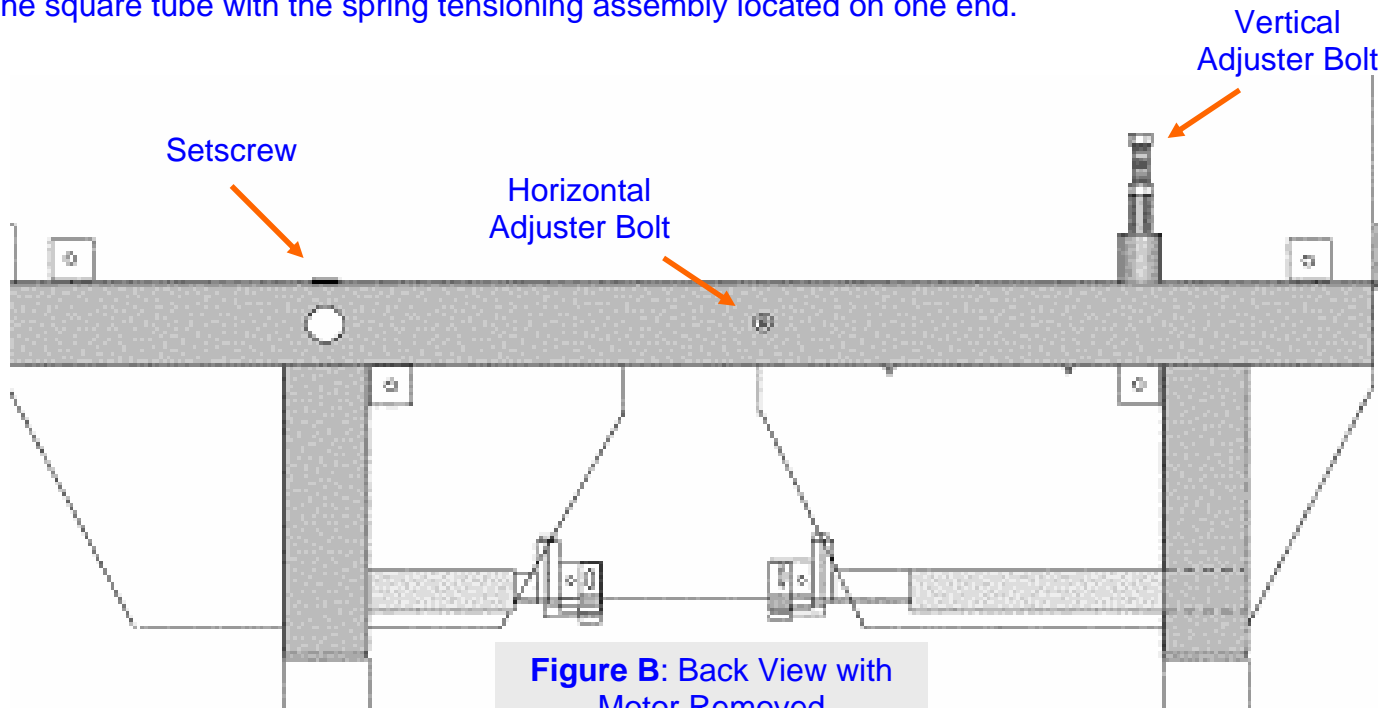

Drive Wheel Adjustments

The drive wheel's position is set in the factory. In most cases it never needs to be moved. It can only be moved in and out, and should only be moved when the wheel is cocked so that the face cannot be lined up with the face of the idler wheel. If you find that you must move this wheel, you will find a set screw located under the rubber dust cap, on top of the square tube, on the back side of the head rig, directly behind the wheel. With this setscrew loosened, the wheel can be moved in or out, or removed completely. If spindle and wheel assembly is moved, the spindle will need to be re-dimpled. Retighten setscrew when finished.

Note: *It is important to re-dimple the spindle after moving or replacing it.*

Idler Wheel Adjustments

When looking at the front of the head rig, the idler wheel is on the left. This wheel is used to adjust tracking problems. Your tracking adjusters are located on the square tube on the backside of the head rig. These two bolts make all of your tracking adjustments. The bolt on the topside of the square tube is used for vertical adjustments. The bolt on the backside of the square tube underneath the motor is used for horizontal adjustments. Use these bolts to tilt the idler wheel so that it is lined up with the face of the drive wheel. When the faces appear to be lined up, fine-tune it using the following procedure.

Vertical Adjustments

- ❑ Rotate the wheel several rotations counterclockwise. Examine the positions of the back of the blade on the wheel at the top of the wheel and compare it to its position at the bottom of the wheel. The blade position should be the same in both locations on both wheels. If not, proceed to the next step.
- ❑ If the blade needs to come forward at the top of the wheel, turn the vertical adjuster bolt clockwise. If the blade needs to go back at the top of the wheel, loosen lock nut then turn the vertical adjuster bolt counterclockwise.
- ❑ Manually turn the wheel several rotations and check the tracking as noted in the first step above. If vertical tracking is still not correct, repeat the procedure until the blade position at the top and bottom of the wheel is the same (both idler and pull wheels).
- ❑ Rotate the wheel several rotations clockwise and repeat the procedure, then tighten lock nut.

Note: *When blade is tracking properly, the blade gullet should be flush with the front side of the wheels.*

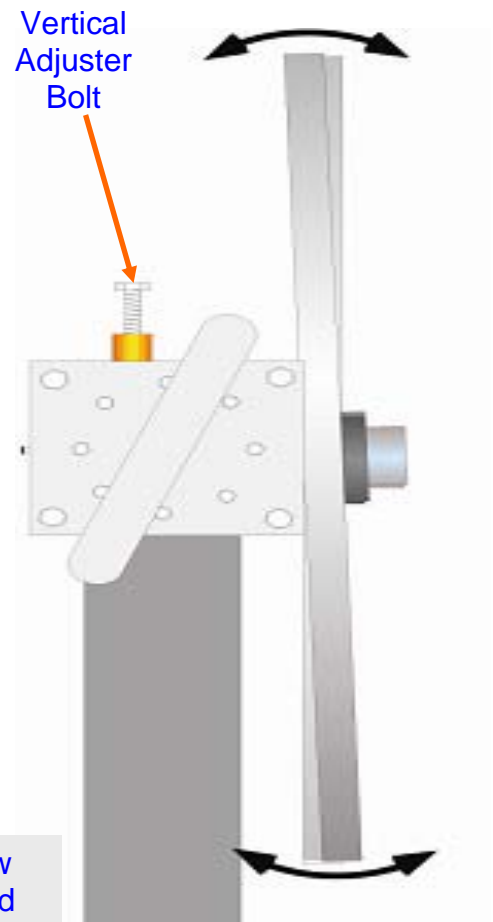
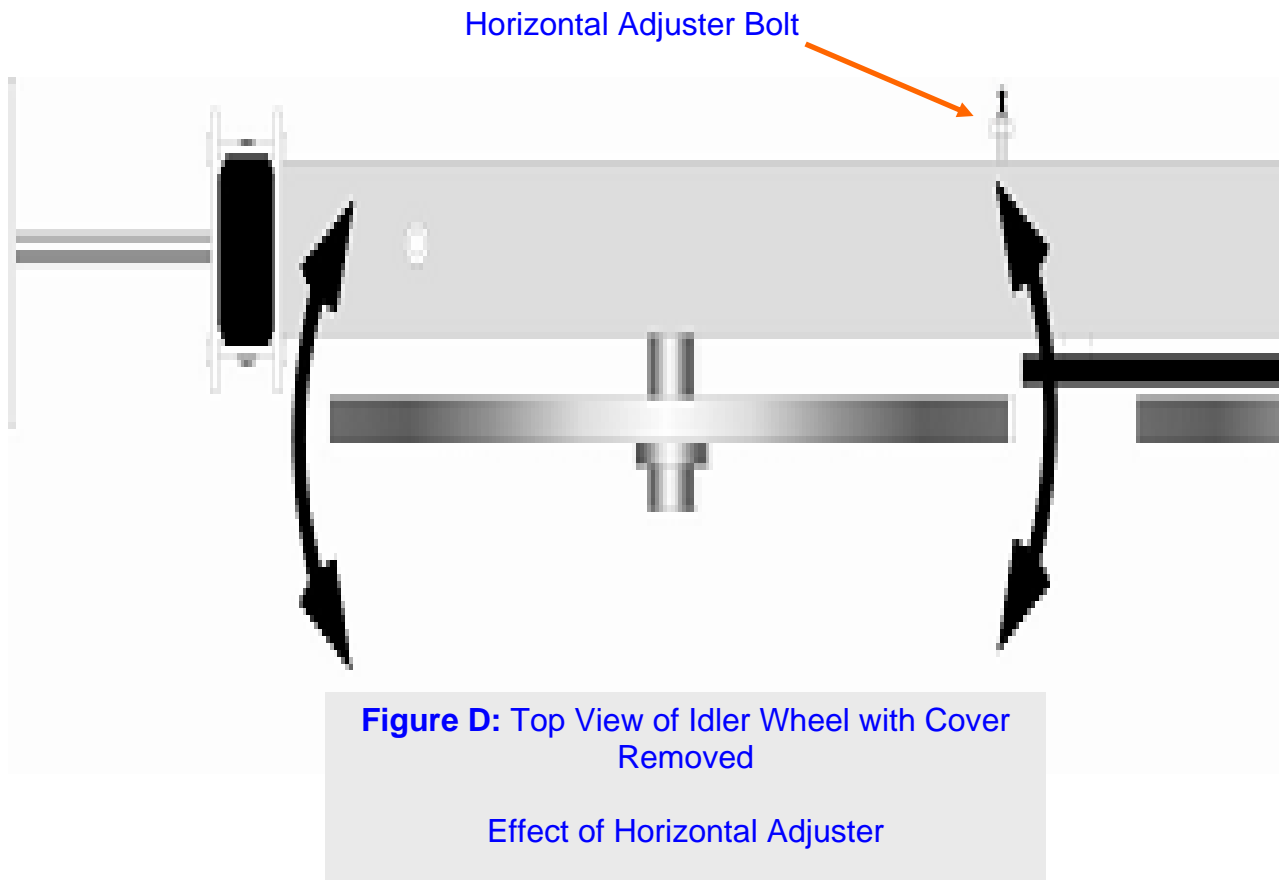

Figure C: Vertical View with Covering Removed

Horizontal Adjustments

- ❑ With the vertical alignment set correctly, compare the blade's position at the top and bottom to its position on the left side of the wheel. If it is not the same, proceed to the next step.
- ❑ If the left side of the wheel needs to go "back," turn the horizontal adjuster bolt clockwise. If the left side of the wheel needs to come forward, turn the horizontal adjuster bolt counter-clockwise.
- ❑ Of course, you'll need to loosen the lock nut first. And, don't forget to retighten the lock nut when finished adjusting.
- ❑ Manually turn the wheel several rotations counterclockwise and check the tracking as in first step above. If horizontal tracking is still not correct, repeat procedure until blade position on the left side of wheel is the same as the top and bottom. Do the same after rotating the wheel clockwise.



Cutting Angle Adjustments

If your Baker starts producing boards that are not square, your cutting angle may need to be adjusted. Before proceeding, though, make sure your guides are set properly (see “**Setting Guides**”) and your blade tracking is correct (see “**Blade Tracking**”).

Check the conveyor belt and look for an obstruction that may be caught underneath the belt. If everything listed above is okay, then continue.

Determining the Problem

- ❑ Start by moving the guides away from the blade. The guides should not be touching the blade in any way.
- ❑ Get two metal plates of the same thickness, approximately ½” x 6” x 4”.
- ❑ With the machine off, locked out and tagged out, place one of the metal plates on the conveyor about 5 inches in front of the blade and the other about 5 inches behind the blade. Set the blade height to the thickness of the metal plates.
- ❑ Use a straight edge to lie across the metal plates and over the blade. Be sure the straight edge is between the teeth, because the set will give you inaccurate measurements.
- ❑ Using this method, you will easily be able to determine if the front of the blade is tilted up or down.
- ❑ If the blade is tilted in this manner, the cutting angle needs front-to-back adjustment. Always make the front-to-back adjustments first.
- ❑ To determine whether a side-to-side adjustment is necessary, measure the distance from the blade to the main conveyor beam at the right and the left of the conveyor. Both distances should be identical. If not, make a side-to-side adjustment.

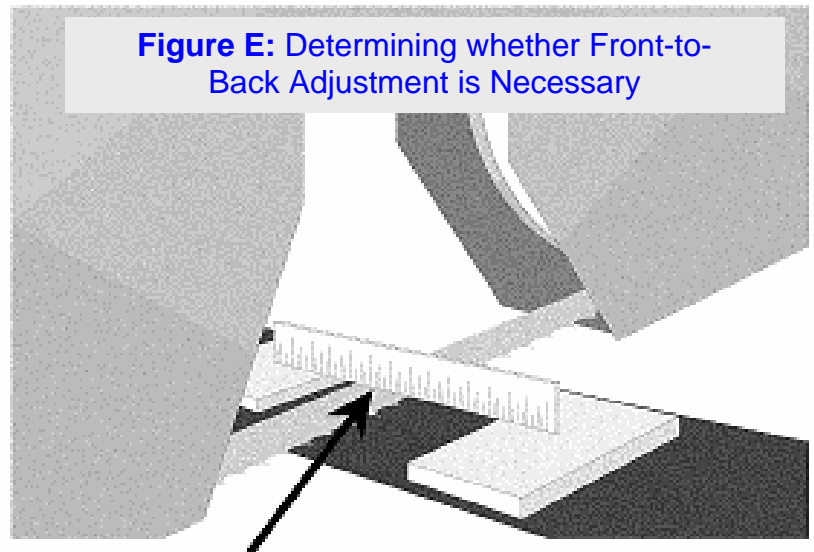

Blade should be 1/32” higher in front

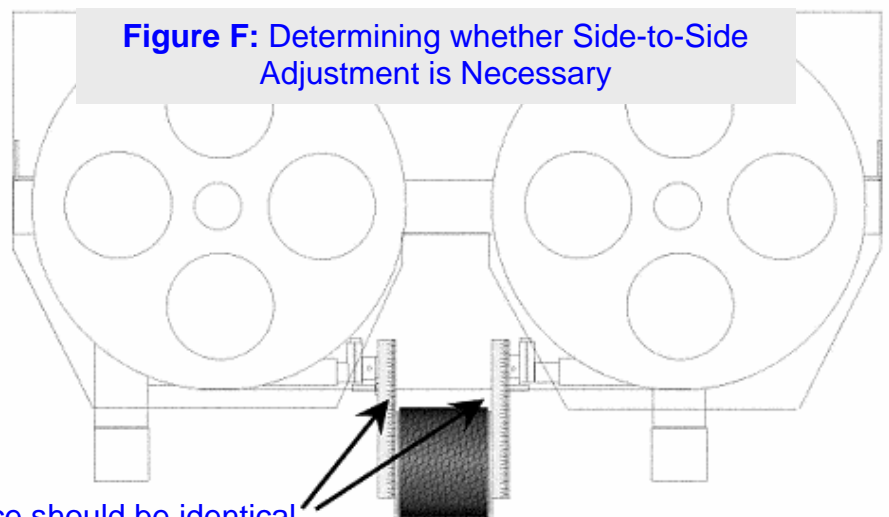

Distance should be identical

Front-to-Back Adjustments

The head is leveled at the factory. It is leveled so that the front of the blade is 1/32" higher than the back. If there is ever a need to adjust this setting, it should be very minor.

If you must make these adjustments, the front-to-back adjusters are located below the head rig. They are turnbuckles between the lift arms on both sides of the head rig.

- Loosen the lock nuts at the end of the turnbuckles and use them to adjust your front-to-back setting.

Side-to-Side Adjustments

To cut quality lumber, the blade must run parallel to the conveyor. This is preset at the factory. However, if it ever gets knocked out, your Baker AB/ABX is set up so that the side-to-side cutting angle can be fine tuned. This can be done with head rig adjustments.

- Find the front turnbuckle that sits under the front lift arm (there is one on each side). These are your side-to-side adjusters.
- Raise or lower the side you are adjusting until the blade is level or at the desired angle.

Note: *Whatever you do to one side, must be done "opposite" on the other side.*

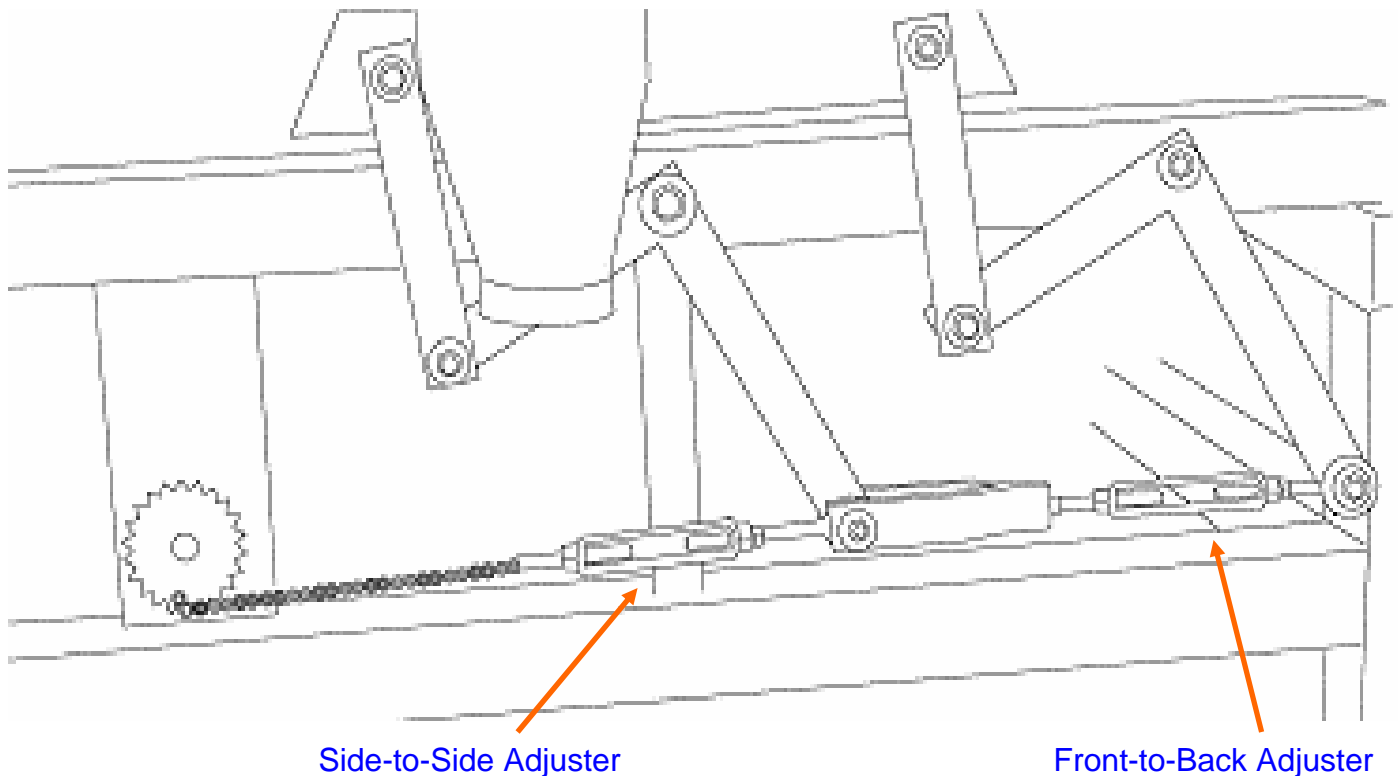

Figure G: Head Rig Adjusters



SETTING GUIDES

Important: *Always make sure blade tracking and cutting angle are set properly before adjusting guides.*

- Turn off power and perform lockout / tagout.
- Adjust guides so that the distance between them is as little as your wood will allow. For example, if you are cutting 6" material, set your guides at 6 1/2" to allow for clearance. Move left guide after loosening the bolt on the backside of the head rig.
- Loosen Upper Guide Plate Bolt and raise Upper Guide Plate up to highest point. Retighten Upper Guide Plate Bolt.
- Loosen the up & down positioning bolts on the back of guide brackets to position the lower plate so that it is lightly touching the blade but not deflecting it. Also, tilt the Guide Block so that it runs parallel to the blade. Retighten up & down positioning bolts.
- Level the guides (on the front to back plane) to the conveyor with the two Tilt Adjusters on the top of each guide arm after loosening the large tilt lockdown bolt. Place the 6" mark of a 12" ruler in the middle of the blade between the blade teeth in the direction of the conveyor. By using the front edge of the guide block as a reference, set this surface at a right angle to the conveyor. Use this to make sure the blade is running parallel to the conveyor. When set properly, lock down the Tilt Adjusters and retighten tilt lockdown bolt.
- Loosen the front-to-back positioning bolts on the guide brackets to bring the front of the guide plates slightly behind the back of the blade gullet. Retighten front-to-back positioning bolts while holding down on the guide so that it is as low as the slot will allow.
- Loosen the guide wheel bolt and turn the shaft of the guide wheel using the slot at the top of the guide until the wheel is about 1/32" from the back of the blade. Retighten the guide wheel bolt. This prohibits the blade from being pushed back far enough that the guide plates knock the set out of the blade teeth.
- Loosen upper guide positioning bolt and move the Upper Guide Plates down to just slightly touch the blade and retighten upper guide positioning bolt.
- Be sure the blade passes freely through the guides but does not move up and down.
- Remove the dust elbow and look into the dust shoot to make sure that the blade runs perfectly straight from one wheel to the other with no deflections due to the blade guides. Also, make sure the position and angle of the guides are identical while looking into the dust shoot.

Guide Illustrations on the Next Page

SETTING GUIDES *(continued)*

The guide wheels are designed for up and down adjustment, so when a groove is worn, you can move it so that it will wear in a different location. As the guide plates wear, they should be moved closer together so that they do not allow the blade to move up and down. The plates should be as tight on the blade as possible without inhibiting the blades movement.

Eventually, you will have to replace worn guide wheels and plates. You should always keep spare guide wheels and plates on hand. Under normal use, guide plates should last about 6 months if they are set properly. If your guide plates are lasting significantly less than this, you probably do not have your guides adjusted properly.

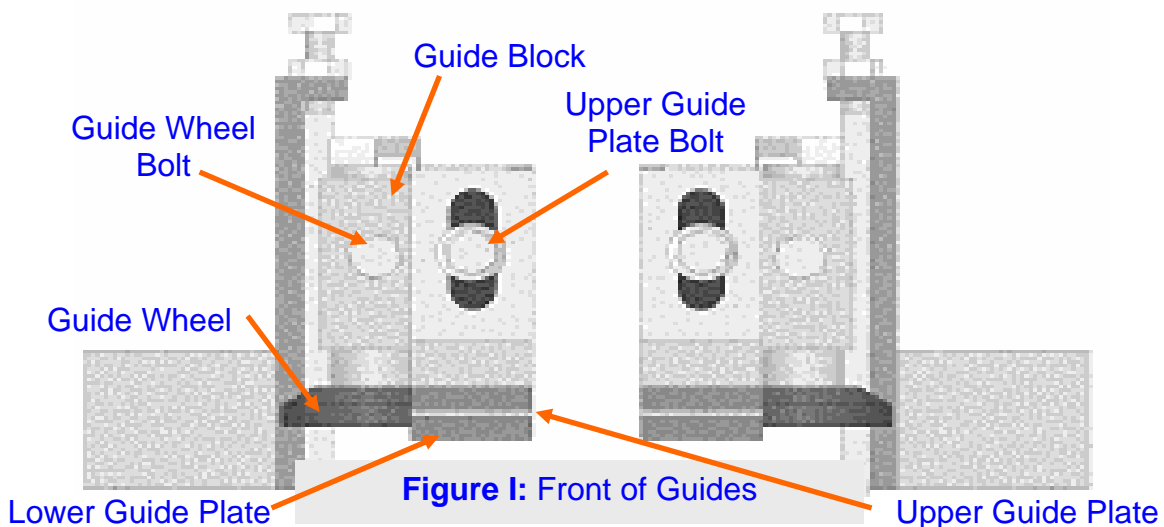
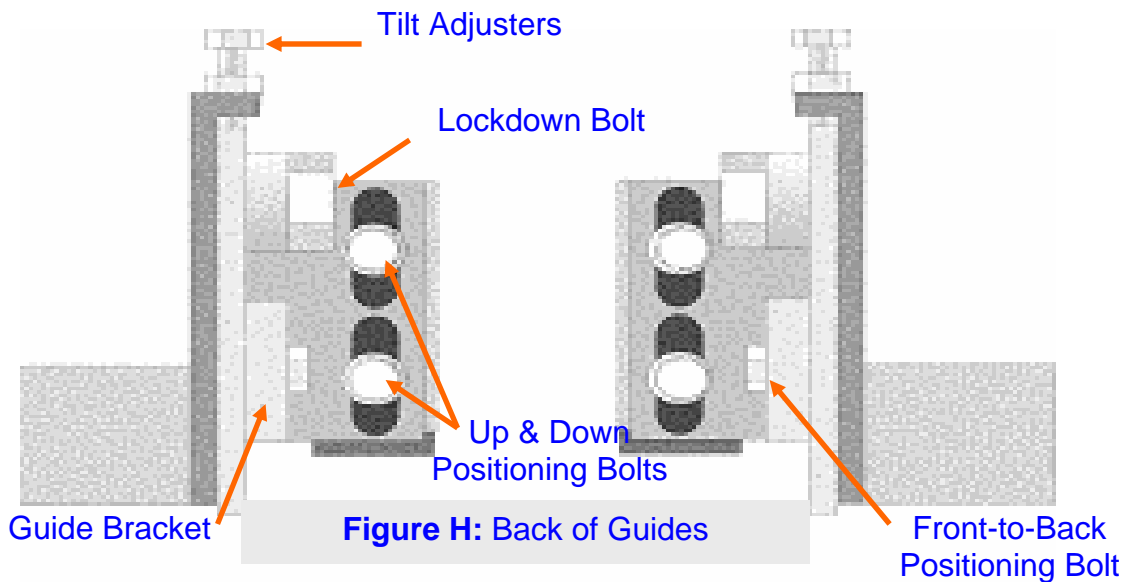

FEEDWORKS

Feed Speed

When the Feedworks Start/Stop Knob is pushed down, the Feedworks is stopped. To start the Feedworks, pull the knob up.

Note: Always make sure the Feedworks Start/Stop Knob is down (off) when starting the saw.

The feed speed can be adjusted from 0 to 95 feet per minute with the Feed Speed Control Arm located on the backside of the head rig. When the arm is pointed down, the Feedworks should be motionless. As you swing the arm up, the feed speed will increase. The arm can be locked into place with the knob located on the arm. Make sure this knob is loosened when you wish to move the arm. You will want to experiment to find the best speed to run your wood types.

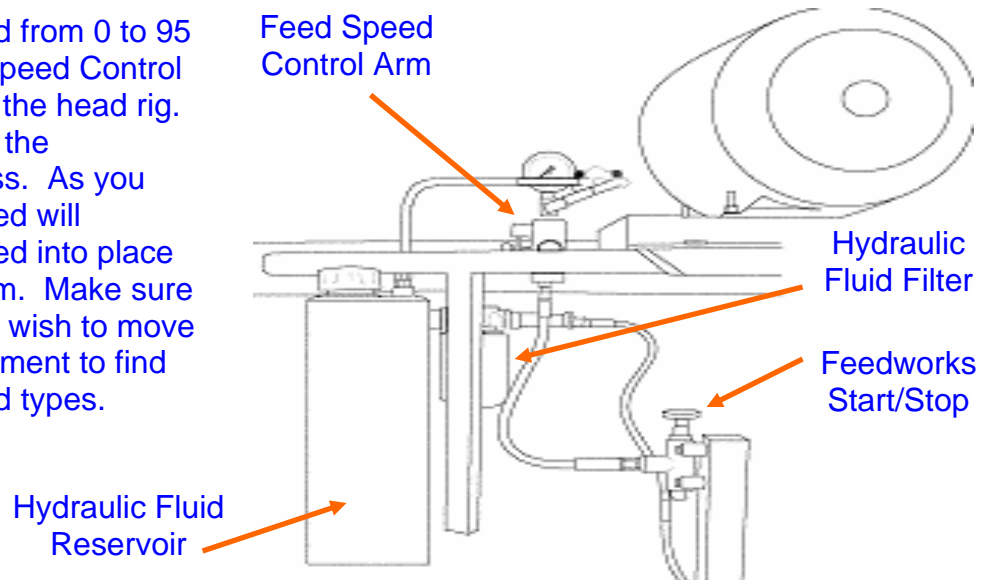

Figure J: Feedworks Assembly

Hydraulics

The Feedworks uses a hydraulic pump driven off of the main drive motor. Dextron II Transmission fluid is recommended.

Conveyor Belts

If the conveyor belts ever need to be adjusted or replaced, use the belt extenders on the in-feed end of the machine. Each conveyor has two belt extenders on the in-feed end (*one on each side*). These should be used to tighten or loosen the belt conveyor.

These adjustments should also be used to align the belt. With the Feedworks empty and in motion, adjust one side until the belt is tracking perfectly.

Loosen locking bolts to allow for adjustments

Re-tighten when finished

Figure K: Conveyor Belt Adjuster Arm (*one on each side*)

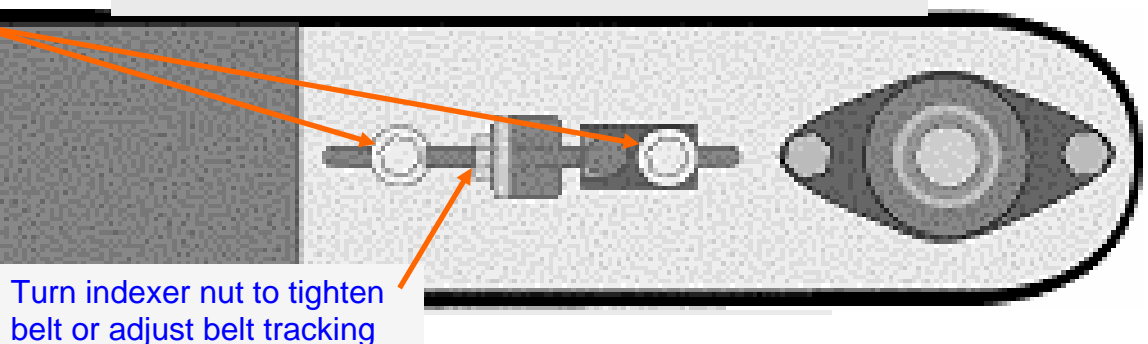

Turn indexer nut to tighten belt or adjust belt tracking

Powered Hold-Down

The Baker AB/ABX is equipped with powered hold-down that holds the wood in place while it is being cut. It can be placed closer to or further away from the blade by loosening the (2) front-to-back bolts on top of the hold-down assembly.

Another (2) bolts on the front of the assembly allow the hold-down to move from side to side or be completely removed.



Figure L: Powered Hold-Down



OPTIONAL EQUIPMENT

Return Conveyor and Simple Slide Return Options

If you did not order a return conveyor but wish to add it now, simply call and order it, then follow these directions for installing it:

- Drain the fluid from the **Baker AB/ABX** into a clean reservoir so it can be reused.
- Position the Return Conveyor and thread the supplied bolts into the side of the conveyor and through the holes on the side of the **Baker AB/ABX**. Put the nuts on the exposed end of the bolts and tighten.
- Connect the hydraulic motor to the Feedworks Start/Stop Assembly with the supplied hoses.
- Tie up the hoses so that they are out of the way.
- Refill the tank with hydraulic fluid.
- Run the saw.

Side Mounted Holdover Wheels

This option improves the versatility of your **Baker AB/ABX**. This is a holdover wheel much like the system found on the larger Baker Band Resaws. With it, you'll be able to rip lumber and size. It provides better overall stability no matter what you cut.

If you did not order your **Baker AB/ABX** with holdover wheels, you can order them any time and install them yourself.



BLADES

The standard **Baker AB** uses the following blades:

- 13' – 2" x 1" x .035 2T Woodmaster C Band Blades

The standard **Baker ABX** uses the following blades:

- 14' – 2" x 1" x .035 2T Woodmaster C Band Blades

NOTE: 1-1/4" guide plates as well as other blade widths, thickness and tooth spacing are available upon request.

Ask your sales consultant or the customer service department for details.

Blade usage is approximately two blades per day per head during full production. Use this figure when ordering your blades until you have developed some record of blade usage for your operation.

Using high quality blades is an important factor in achieving the highest performance out of your Baker AB/ABX band resaw. Our machines are tested and set-up using Lenox blades sold by Ellington Industrial Supply. These are very good blades for use on the Baker and come highly recommended by the majority of Baker owners. If you would like more information on these blades, contact:

Customer Service Department
Ellington Industrial Supply Co., Inc.
PO Box 128
Ellington, MO 63638 USA
Tel: (573) 663-7711
Fax: (573) 663-2787

MAINTENANCE TASKS AND CHECKLIST



Note: Follow Lockout / Tagout prior to performing any checks or maintenance.

Daily

- Use an air-hose to blow-off the dust and wood chips that accumulate in and around the machine, especially the wheels.
- Check band blade tracking
- Check head rig v-belts
- Check guides for adjustment
- Check proper conveyor belt tracking

Note: The machine operator is closer to the operating mechanism of the machine during clean up than during production – extra care should be taken.

- Do NOT clean with flammable or combustible materials.
- Follow applicable codes and standards with regards to:
 - Ventilation and monitoring of work area for excessive accumulation of hazardous vapors
 - Wearing personal protective equipment for handling materials
 - Using proper procedure for disposing of all waste materials

Weekly

- Check chain works and tighten as needed and lubricate with grease
- Check for worn master links
- Check all setscrews
- Check 1:1 gear box v-belt
- Grease 28" wheel bearings

Monthly

- Grease slow moving bearings
- Check gear box and variable speed drive for leaks

Every 3 Months

- Motors should be greased with one pump of grease from a grease gun

Once a Year

- Clean 28" wheel bearings and re-pack or replace if worn.

TROUBLE SHOOTING

Note: Always check blade tension, blade quality, and guides before attempting any other adjustments. Always keep a blade on hand that you know cuts well. Put this blade on the machine to make sure the problem isn't the blade.

Boards that look like the image below usually occur after you wreck the saw. A hard piece that accidentally gets hung up in the saw messes up your guide alignment. See "**Setting Guides**". A last alternative would be adjusting the head rigs. See "**Cutting Angle Adjustment**".



Boards that look like the image below are almost always problems with the blade. A blade with more set on the top or with dull bottom teeth will cut bowed boards. Check with a good blade. If it is not the blade, check blade tension.



Boards that look like the image below are usually blade problems. Ripples form when the blade has more set on the bottom. Check with a good blade. If it is not the blade, check blade tension.



Loose guide plates or improper blade tensioning can generally cause boards to look like the image below. (See "**Changing Blades**" or "**Setting Guides**"). These boards can also result from extreme damage to the tilt of the holdover wheels.



Parts and Service Recommended Spare Parts List

Part No.	Description	Part No.	Description
141003 	1" Top Guide Pad – QTY (2)	141013 	1 ¼" Top Guide Pad – QTY (2)
141004 	1" Bottom Left Guide Pad – QTY (2)	141014 	1 ¼" Bottom Left Guide Pad – QTY (2)
141005 	1" Bottom Right Guide Pad – QTY (2)	141015 	1 ¼" Bottom Right Guide Pad – QTY (2)
121006 	#50 Roller Chain – QTY (as needed)	121007 	#50 Connector Link – QTY (10)
141001 	Roller Guide Wheels - QTY (2) per Head	111013 	5VX710 Drive Belt -- QTY (2)
101275 	Bearing for 28 in Wheel (4 Bolt Hole) - QTY (1) per Head	171077 	Spindle Nut N-11 – QTY (1)
181015 	Hydraulic Pump (If equipped w/ hyd. Feedworks) QTY - (1)	181019 	Hydraulic Filter (If equipped w/ hyd. Feedworks) QTY - (1)

Service Contact Information

In the event that you have any problems, call us at (573) 663-7711 any time between 8:00 AM and 5:00 PM (CST), Monday through Friday.

Serial Number Location

The model and serial number are located on the front side of the machine near the operator station.

Please refer to your serial number and model number when speaking to a service technician or ordering replacement parts.

Wiring Diagrams

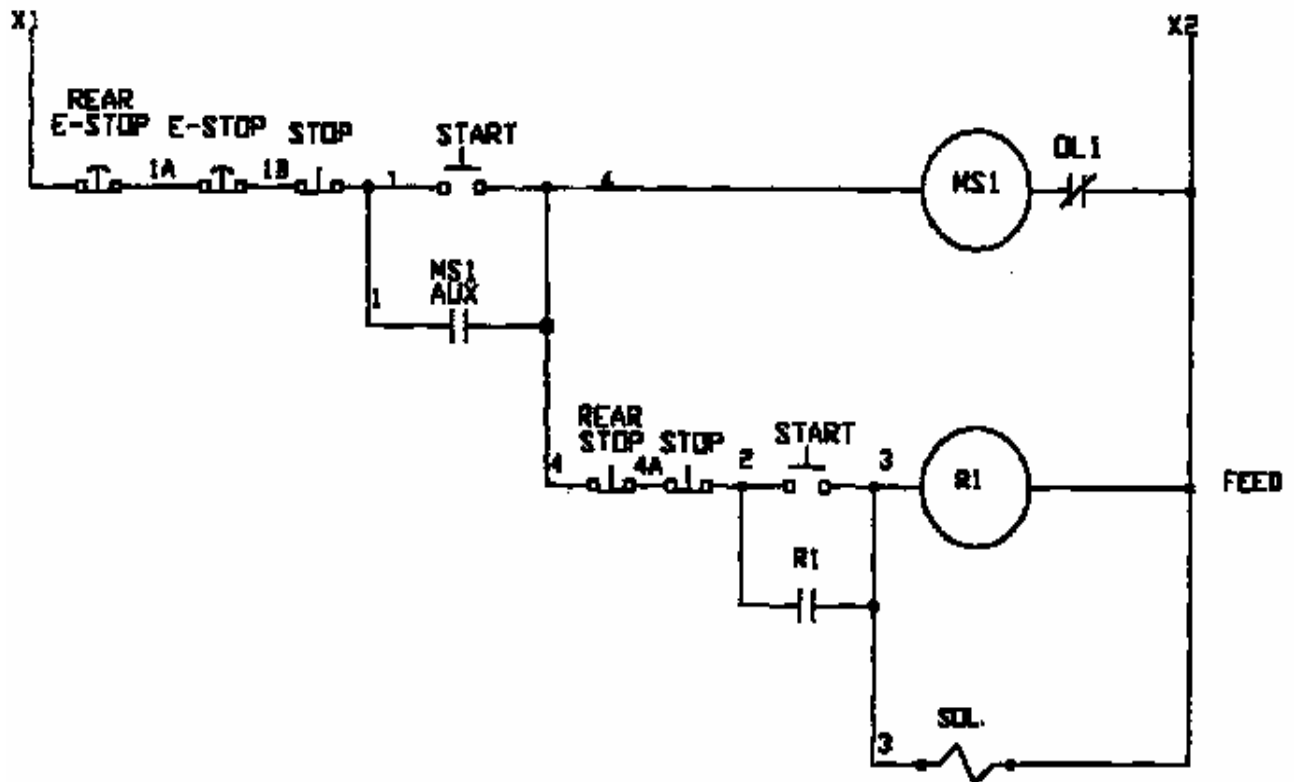
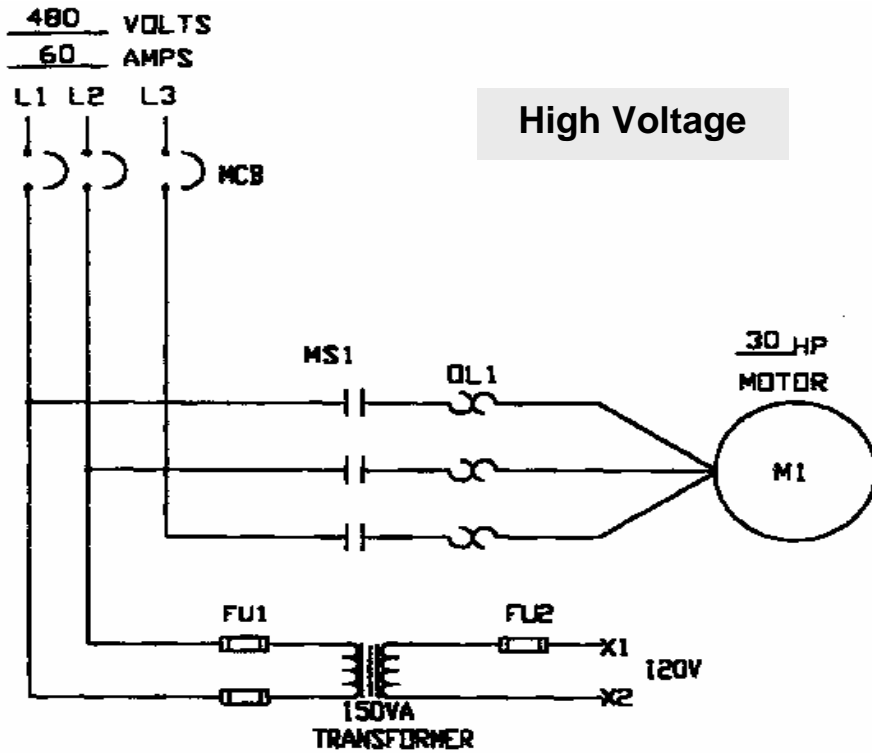

Wiring Diagrams *(continued)*

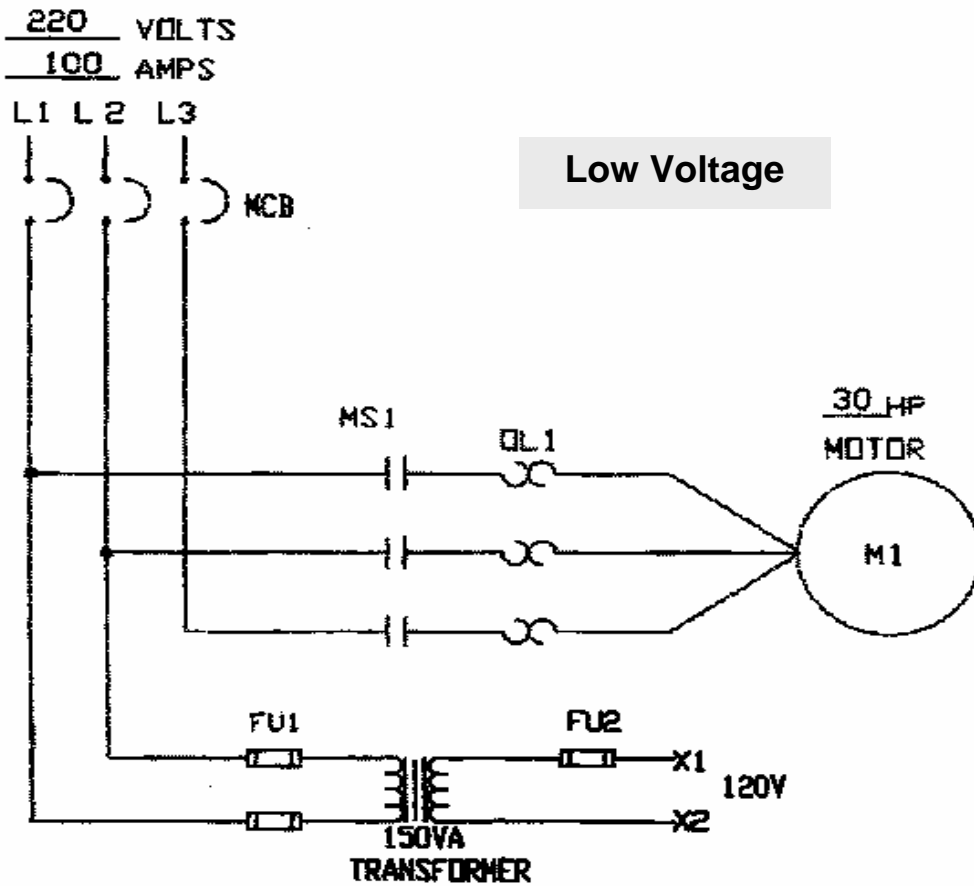

Low Voltage

